

Hydrocarbon Upgrading Demonstration Program (HUDP)

Presentation to Hydrocarbon Upgrading Task Force

Duke du Plessis
Alberta Energy Research Institute
and
Alberta Employment Immigration and Industry

McDougall Centre
Calgary, Alberta

20 June 2007

Hydrocarbon Upgrading and Demonstration Program (HUDP)

- Alberta “Vision” – paraphrased
 - Become a world leader in commercializing new technologies to utilize Canadian heavy hydrocarbons with positive economic, social and environmental impact
 - Demonstration Units: Accelerate commercialization of new technologies by closing the gap between pilot plant and commercialization
 - Training of skilled personnel
- HUDP Phase 1 study commissioned by:
 - Alberta Energy Research Institute (AERI), Nova, Husky, Nexen, CNRL, Suncor, Peace River Oil, Shell Canada
- Identify and evaluate “next generation” technologies with “*breakthrough potential*”

Hydrocarbon Upgrading Demonstration Program (HUDP) –Phase 1

- Contracted Jacobs Consultancy
- Screened 100 technologies and 25 licensors
- Evaluated 17 technology configurations:
 - conventional 200,000 bpd reference plant for SCO
 - Refined products & petrochemicals
- Selected technologies with best potential
- Technologies ranged from early stage conceptual to more mature, ready for demonstration processes

HUDP Phase 1- Representative Process Schemes and Products

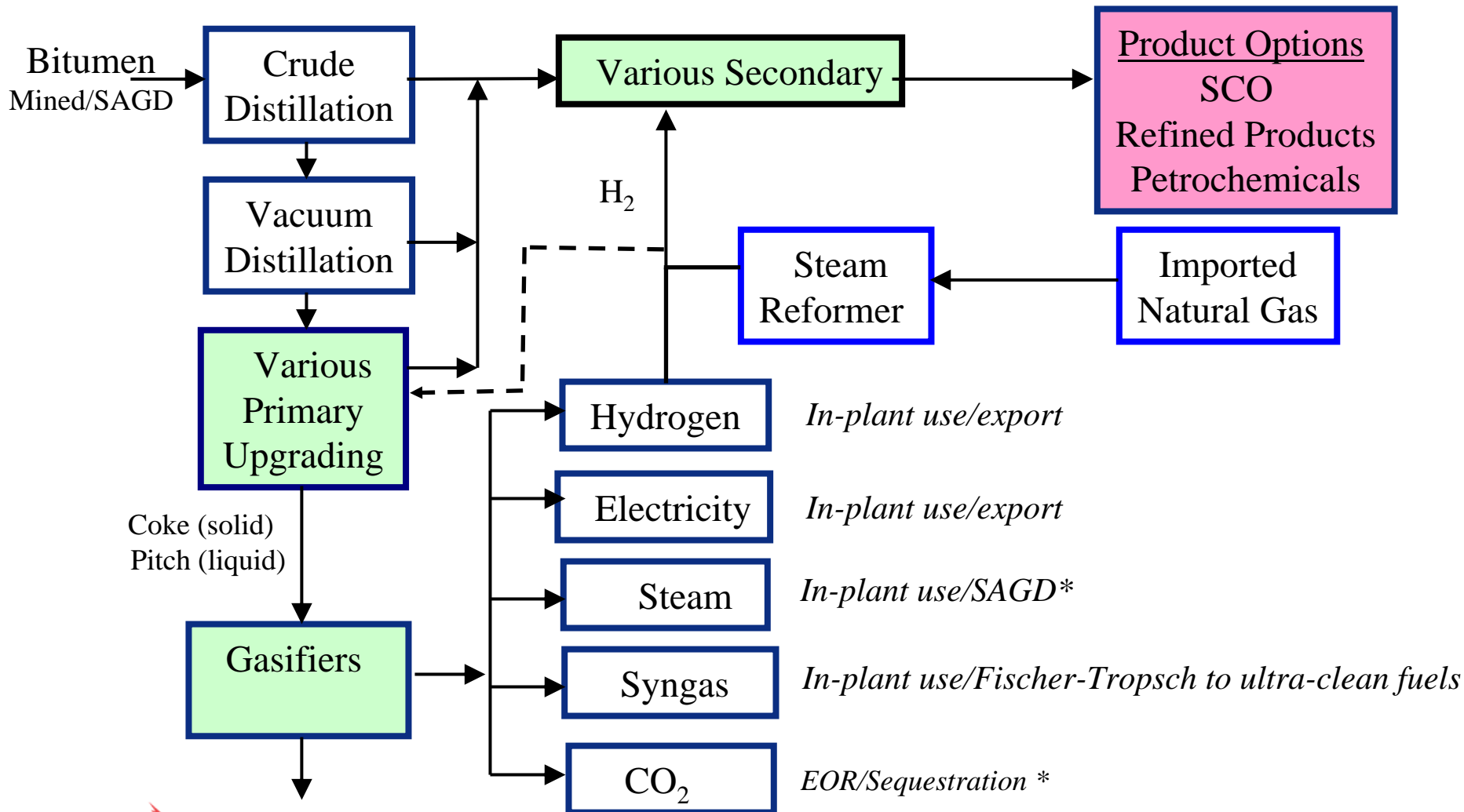

* not included in Phase 1 of AERI/Industry study

HUDP Phase 1

General Conclusions

- Overall conversion improves economics to a point
 - Optimum residue make versus capital and operating cost
- Gasification economics attractive especially at high NG prices
 - Challenges - capital cost and reliability

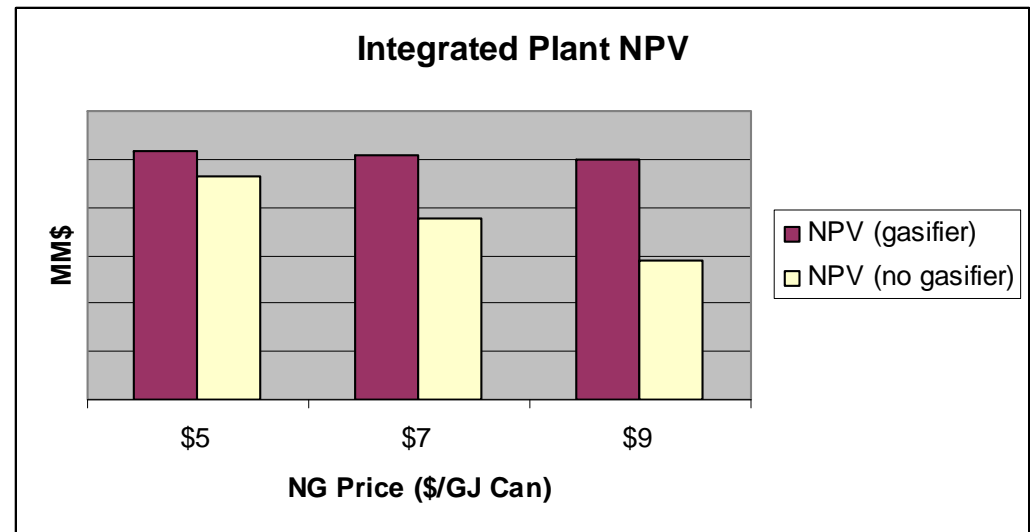
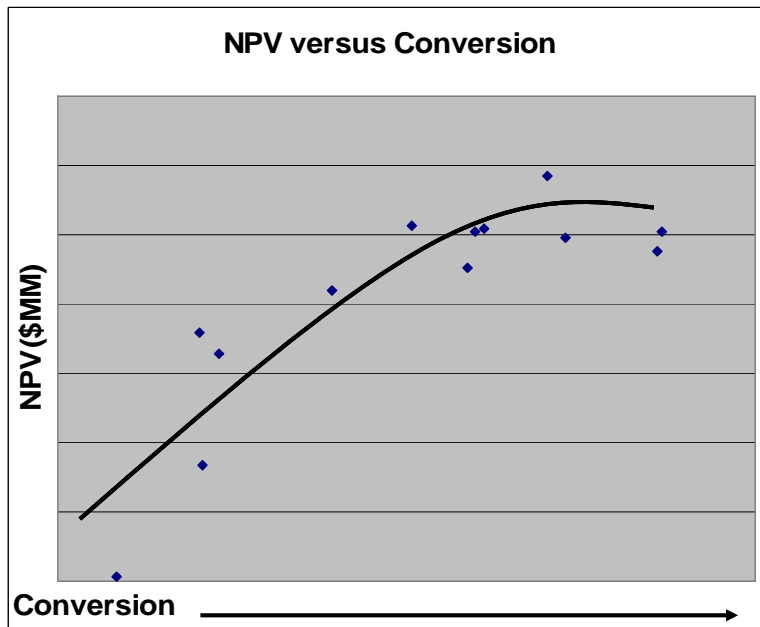

Environmental – Gasification versus SMR

Upgrader Coke and CO₂ emissions

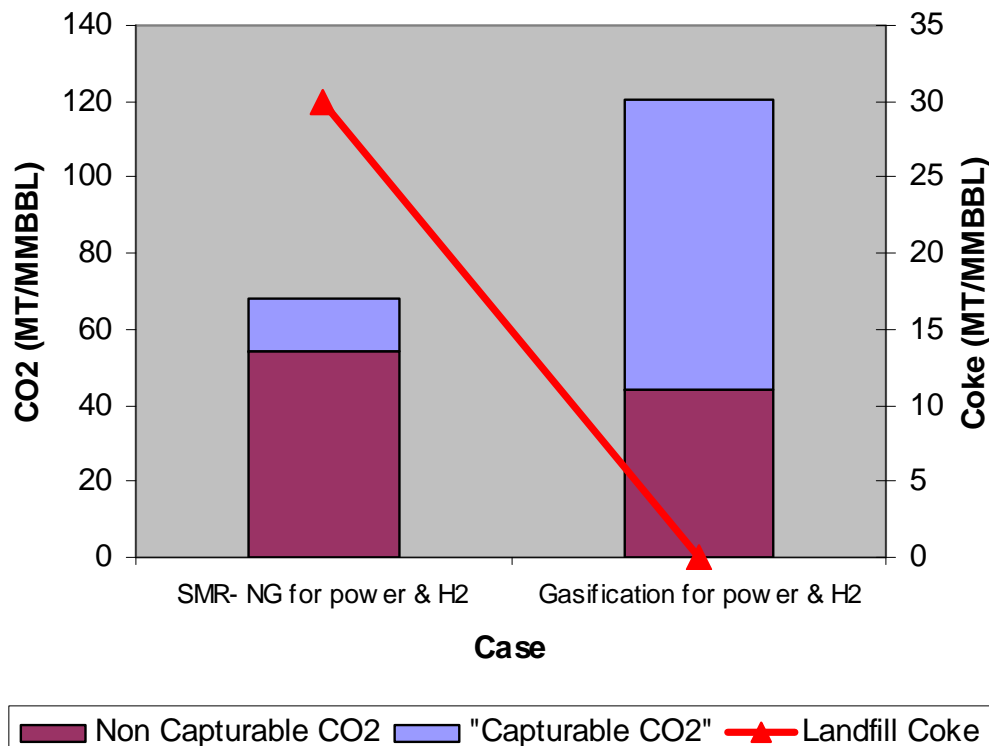

- Upgrader producing finished products
- Gasification reduces
 - non-capturable CO₂
 - Coke storage

Gasification Reduces the Environmental Footprint of Upgrading

HUDP Phase 2

- AERI requested expressions of interest for “Next Generation” Carbon/Hydrocarbon Upgrading Technologies – Nov 2006
- Received 23 proposals.
- Identified best for full applications
- Selected 8 for stage-gated funding
 - Residue Upgrading (3)
 - Gasification (3)
 - Bitumen to Petrochemicals (1)
 - CO2 capture (1)

ETX Cross Flow Coking

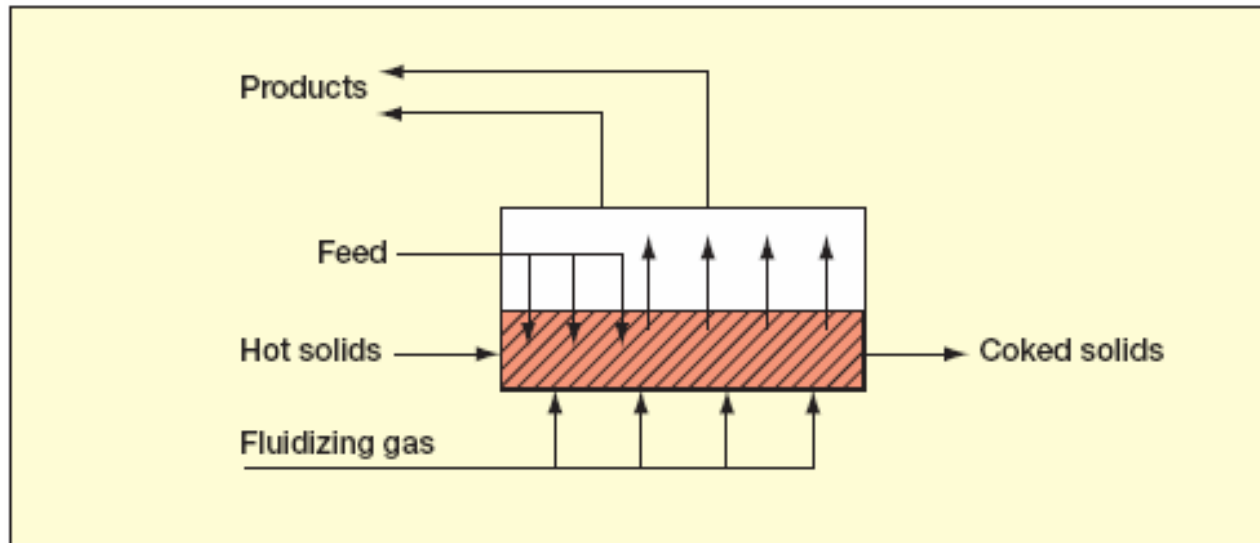

- Claims:
 - Improved conversion compared to delayed coking
 - Lower coke yields
 - Improved product yield and same qualities
 - Capital savings
- Pilot plant work progressing to validate yield and qualities
- Seeking other participants

UOP - Residue Upgrading

- Proprietary technology
- Claims:
 - 90+% conversion of bitumen to 525°C and lighter products
 - Optimum Integration with secondary upgrading (hydrotreating/hydrocracking)

NOVA NHC and ARORINCLE

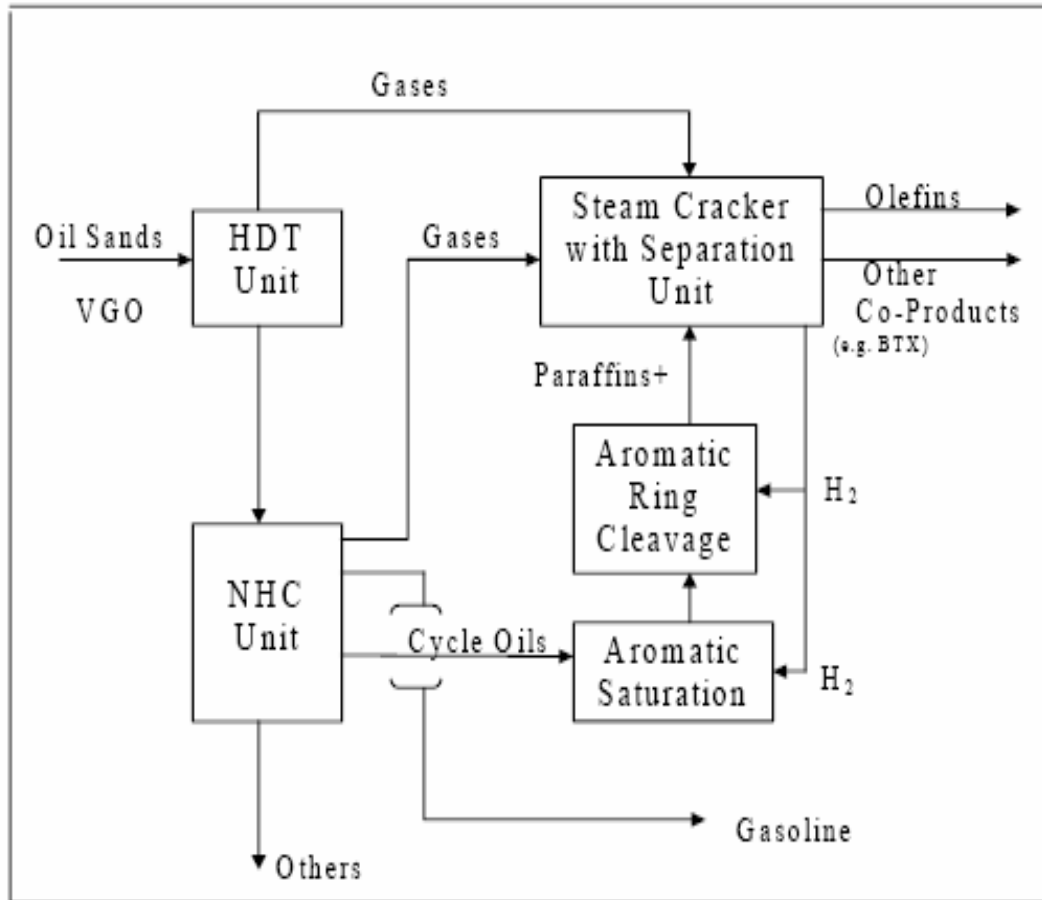

Diagram is courtesy of NOVA Chemicals

- Proprietary technology based on extensive catalyst development
- High yield of C₂, C₃ (including olefins) and BTX from bitumen
- Benefits of integration with upgrading & refining

PWR Gasification- Claims

- Based on rocket engine technology
- High mass flux
- Advanced materials
- Size and cost reduction

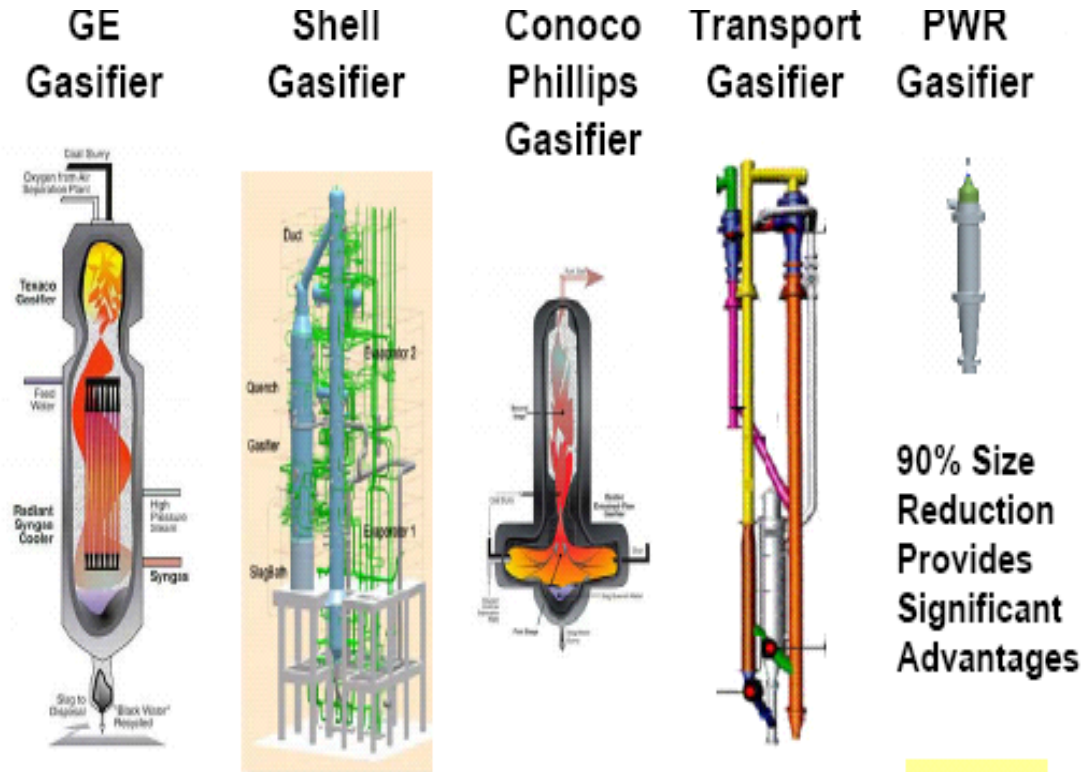
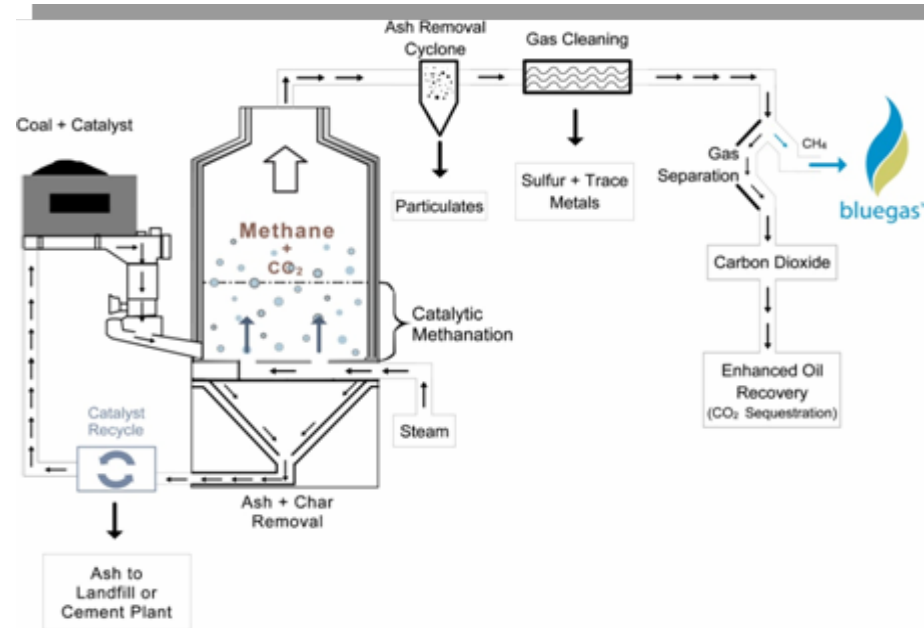

Diagram Courtesy PWR

	GE Gasifier	Shell Gasifier	Conoco Phillips Gasifier	Transport Gasifier	PWR Gasifier
• Capital Cost	Base	>Base	Base	Base	<50%
• Availability	0.90	0.85 ↑	0.82 ↑	?	0.99
• Cold Gas Efficiency	0.77	0.83	0.83	0.75	0.85
• Fuel Flexibility	Fair	Good	Fair	Poor	Good
• Product Flexibility	Good	Fair	Fair	Poor	Good

Great Point Energy (GPE) Catalytic Gasification

- Converts petcoke/coal to methane (SNG) in single stage reactor
- Steam instead of oxygen saves cost of ASU
- Produces SNG at low end of NG market price
- SMR of SNG lower capital cost than gasifier with shift and PSA



Summary

- HUDP is progressing on schedule
- Phase 2 focuses on developing and demonstrating promising “next generation” clean upgrading technologies in partnership with industry
- Technologies selected are at different stages of development
- Government/Industry risk sharing essential to demonstrate commercial readiness
- Opportunity for wider industry participation in selected development and demonstration projects

Contact Information

*Eddy Isaacs, Executive Director,
Alberta Energy Research Institute
Suite 2540, 801 – 6 Avenue SW,
Calgary, AB T2P 3W2
eddy.isaacs@gov.ab.ca
Tel. (403)297-5219*

*Duke du Plessis, Senior Advisor and Research Manager
Alberta Energy Research Institute
Suite 2540, 801 – 6 Avenue SW,
Calgary, AB T2P 3W2
duke.duplessis@gov.ab.ca
Tel. (403)297-3635*